



# Achieving More with Less: How to Obtain the Benefits of SAN Storage Without Breaking the Bank

---

## White Paper

By Andrew Melmed, Director of Enterprise Solutions, Sanbolic, Inc.

May 2010



[www.sanbolic.com](http://www.sanbolic.com)



## Introduction

There's a well-known proverb that says... *"You can't have your cake and eat it too!"* And while this may apply to a lot of things, there's no rule that says it has to apply to data storage. In fact, it can actually be quite easy for organizations to create robust, flexible, easy-to-manage storage solutions that allow them to realize far greater returns on the investments in their application, server and storage infrastructures, without digging deep into their coffers to do so.

This paper explains how organizations can achieve many of the inherent benefits of Storage Area Network (SAN) storage, including higher levels of performance, scalability, reliability and availability, without incurring many of the costs associated with procuring, operating and maintaining SAN storage hardware (i.e., storage arrays, switches, HBAs, fiber cables, power and cooling, etc.).

## Achieving more with less

Using industry-leading SAN software from Sanbolic® and industry-standard server hardware, organizations can create software-based storage solutions that are comparable in terms of performance, scalability and availability to more expensive small- to mid-range hardware-based storage solutions, at a fraction of the cost.

The key to constructing a cost-effective software-based storage solution, or **"Soft-SAN,"** lies in the ability to reuse hardware already in one's possession. By reusing or repurposing equipment which is not currently in service, organizations can leverage previous investments in their hardware and network infrastructures to garner the benefits of block-based storage. In addition to saving on hardware costs, organizations can also realize significant savings in time and energy, both of which may be heavily consumed while conducting the research necessary to determine which SAN hardware best meets their needs as well as their budgets.

## Anatomy of a Soft-SAN

A Soft-SAN is a highly scalable and highly available storage system that allows multiple Windows® servers to share simultaneous block-level access to storage volumes whose data is protected via software-based RAID 1 (mirroring).

Soft-SANs are comprised of the following components:

- **Storage Hosts:** Two or more physical Windows Servers (Server 2003™ R1, R2 x64; Server 2008™ R1 x86 or x64; Server 2008 R2 x64) running on industry-standard server hardware, each containing a RAID controller and a minimum of three hard drives
- **Storage Clients:** Two or more physical or virtual Windows Servers (Server 2003 R1, R2 x64; Server 2008 R1 x86 or x64; Server 2008 R2 x64), each with a minimum of three network interfaces
- iSCSI Software Initiators
- iSCSI Software Targets
- Sanbolic Melio 2010™ SAN software



Robust, flexible and easy to manage, Soft-SANs allow organizations to improve the performance, scalability and availability of their application, server and storage infrastructures, without bearing the costs of installing, configuring and maintaining hardware-based SANs.

An ideal storage solution for SMBs, Soft-SANs can also be extremely useful in larger enterprise environments as well. For example, Soft-SANs can provide a cost-effective way for users in remote offices or within individual departments to share access to critical files or data that must be available at all times to maintain business continuity. They can also provide organizations battling limited budgets with the ability to add more servers and more storage resources on the fly whenever unexpected situations arise that require improvements in I/O performance or additional storage capacity. Offering high availability and scalability, Soft-SANs possess the unique ability to address a wide range of use cases quickly and easily, at very little cost.

## About Sanbolic Melio 2010

The driving engine behind a Soft-SAN is **Sanbolic Melio 2010**, a feature-rich software product suite comprised of various applications that are designed to work together to simplify, share and enhance SAN storage.

At the core of Melio 2010 is an advanced, 64-bit symmetrical cluster file system called “Melio FS” that allows multiple servers to share simultaneous read-and-write access to block-based storage. As an all-purpose cluster file system, Melio FS supports all workload types and extremely large storage volumes.

Melio 2010 also includes a host-based cluster volume manager that greatly simplifies the management of Melio shared storage by creating virtual pools of storage (logical volumes) out of physical storage resources (hard disks), while providing advanced functionality such as the ability to create volume sets and stripe sets to improve I/O performance, as well as expand logical volumes dynamically to meet future growth needs.

Using Melio 2010, applications can share access to data at block-level through dedicated I/O paths between storage clients and hosts without introducing any of the constraints associated with file-based shared storage solutions (i.e., locking contention incurred by CIFS and NFS in mid- to larger-size file-sharing environments; bandwidth saturation resulting from the shuttling of storage and application traffic over the same network; single points of failure introduced with file shares or NAS devices; etc.). Sharing access to a single pool of storage allows multiple instances of an application running on multiple servers to work in tandem to achieve significant improvements in performance, scalability and availability, while minimizing storage requirements.

For organizations looking to achieve additional versatility from their Soft-SANs, Melio 2010 also supports network sharing of RAID1 volumes, allowing storage clients to act as NAS heads to provide a highly scalable and highly available file-serving solution that allows workstations (non-storage clients) to access data on the Soft-SAN via CIFS at the same time that storage clients access data on the Soft-SAN at block-level.

Using Soft-SANs powered by Melio 2010, organizations can achieve the following benefits:

- High performance – Block-based access to storage with dedicated I/O paths
- Scalability – Ability to add more servers and more storage resources quickly and seamlessly
- High availability – Data mirroring to ensure data accessibility in the event of a storage host failure
- Simplified management – Ability to manage all storage resources via a central management console
- Data protection – Backup and recovery of data at various points in time using VSS-based snapshots

The following diagram illustrates a highly scalable and highly available Soft-SAN comprised of industry-standard servers and Sanbolic Melio 2010 SAN software.

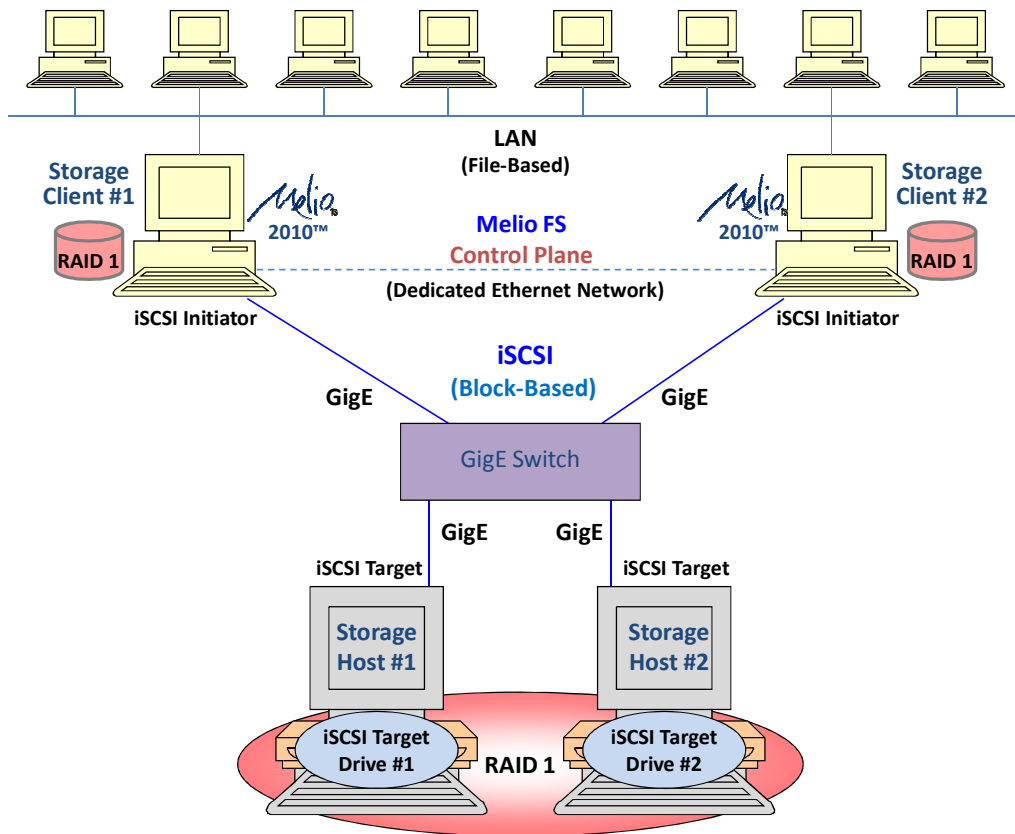

## How to Build a Soft-SAN

The steps outlined below describe how to create a robust, flexible, easy-to-manage Soft-SAN similar to the one depicted in the diagram above.

1. Using two physical servers (storage hosts), install a minimum of three hard drives in each server.
2. Boot up each storage host and enter the BIOS to access the RAID Controller.
3. Within each storage host, configure the disks to operate in a RAID group. **Note: The RAID level you choose will depend on the number of disks you have and the amount of protection you are looking to achieve.**
4. Reboot the storage hosts.
5. On each storage host, use the iSCSI Target software to create a single drive out of each RAID group.
6. Boot up at least two physical or virtual servers (storage clients) and install Sanbolic Melio 2010 SAN software on each server.
7. On each storage client, configure the iSCSI Initiator to establish connections to both iSCSI target drives.
8. On one storage client, launch the Melio 2010 cluster volume manager (*Start > All Programs > Sanbolic > LaScala cluster volume manager*) and follow the instructions in the LaScala Users Guide to create a RAID1 shared volume out of the two iSCSI target drives located on the storage hosts.

Congratulations... you've just created a Soft-SAN!



## Conclusion

Deploying a Soft-SAN powered by *Sanbolic Melio 2010* allows organizations to make much better use of the equipment they already own, ensuring greater returns on the investments in their hardware while achieving many of the inherent benefits associated with hardware-based SANs, including high performance, scalability, reliability and availability. And best of all, organizations can accomplish all of the above without incurring the expenses associated with procuring, maintaining and managing hardware-based SANs.

### Sanbolic Inc.

304 Pleasant Street, 2nd Floor

Watertown, MA 02472

Phone: 617-833-4249

Fax: 617-926-2808

Email: [sales@sanbolic.com](mailto:sales@sanbolic.com)

**Microsoft**<sup>®</sup>  
**GOLD CERTIFIED**  
*Partner*